

PART VI

**REGULATIONS, VOTING PROCEDURES
AND ARRANGEMENTS**

BALLOT BOX REGULATION
LOCAL AUTHORITIES ELECTION ACT

Definitions

1. In this regulation,
 - (a) “seal” means a closing device or method applied to a ballot box in accordance with the Act that must be broken in order for the ballot box to be opened;
 - (b) “tape” means tape that has adhesive on one side and is of sufficient strength that it cannot be removed from a cardboard ballot box without being cut or without defacing the cardboard ballot box.

Permanent ballot boxes

2. Each ballot box shall be made of durable material and constructed that ballots can be deposited into the ballot box and cannot be removed from it unless the seal broken and the ballot box is opened.

Cardboard ballot boxes

3. (1) Notwithstanding section 2, an elected authority may use cardboard ballot boxes if each cardboard box used
 - (a) is constructed of a minimum 175-pound text cardboard,
 - (b) meets the following minimum dimensions, as shown in the Schedule:
 - (i) width, 22 centimetres;
 - (ii) length, 36 centimetres;
 - (iii) height, 36 centimetres;
 - (c) has four flaps at each side, as shown in the Schedule, that meet or overlap when closed and taped, so as to prevent the removal of ballots unless the ballot box is opened by cutting the tape, and

(d) has one slot for the deposit of ballots, the width of which is 0.5 centimetres and location and the length of which is discretionary.

(2) A cardboard ballot box must be closed and must be sealed by closing the flaps and placing a piece of tape over the entire adjoining edges and the ends of the closed flaps, such that the tape prevents the flaps from being opened without first cutting the tape.

Repeal

4. The Ballot Box Regulation (AR 144/2000) is repealed.

Expiry

5. For the purpose of ensuring that this Regulation is reviewed for ongoing relevancy and necessity, with the option that it may be repassed in its present or an amended form following a review, this Regulation expires on October 31, 2009.

Schedule

Minimum Dimensions of a Closed Cardboard Ballot Box

Slot location and slot length are discretionary.
Slot width is 0.5 centimetres.

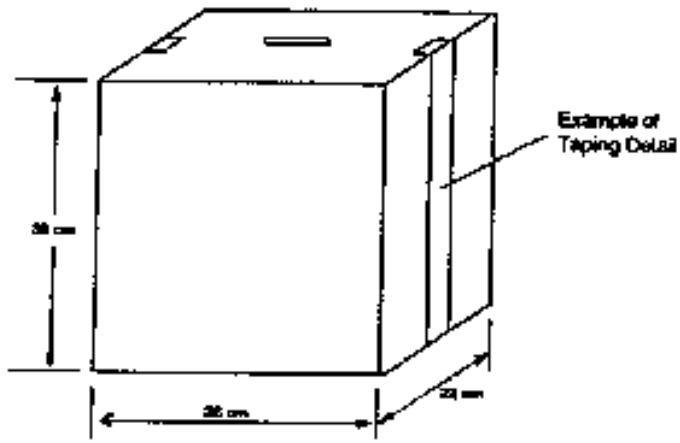

END FLAP FOLDING DETAIL

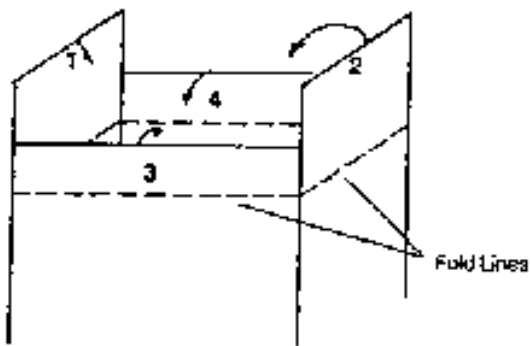

FORMS REGULATION

LOCAL AUTHORITIES ELECTION ACT

- 1 (1) The forms set out in Schedule 1 are the English forms for use under the *Local Authorities Election Act*.
- (2) The forms set out in Schedules 2 and 3 are the forms for use under the *Local Authorities Election Act* for the election of members of a Regional authority as defined in the *School Act*. (not included)
- 2 If a council has passed a resolution under section 155 of the *Municipal Government Act*, the title directed by that council for “councillor” or “chief elected official” is the title that may, in that local jurisdiction, replace councillor or chief elected official on the forms in the Schedules.
- 3 For the purpose of ensuring that this Regulation is reviewed for ongoing relevancy and necessity, with the option that it may be repassed in its present or an amended form following a review, this Regulation expires on October 31, 2017.
- 4 The forms contained in Schedule 1 are found in the Appendix of this document.

REGULATION AR 5/2007

MODIFIED VOTING PROCEDURE REGULATION

LOCAL AUTHORITIES ELECTION ACT

(EFFECTIVE JANUARY 23, 2007)

Definition

1. In this Regulation, “Act” means the *Local Authorities Election Act*.

Designating locations of voting stations

2. Where an elected authority has passed a bylaw in accordance with section 160(2) of the Act, section 37 of the Act is modified as follows:
 - (a) the returning officer of the elected authority may designate the location of the voting station;
 - (b) the location of more than one voting station may be designated for each voting subdivision.

Elector’s statement

3. The statement required under section 77 of the Act is Form 8 as prescribed in Schedule 1 to the *Local Authorities Election Forms Regulation* (AR 378/2003).

Blind voter template

4. Despite section 78(5) of the Act, where an elected authority has passed a bylaw in accordance with section 160(2) of the Act, the returning officer of the elected authority may determine the form of the blind voter template to be provided to an elector under that section.

Appointing deputies to take votes of electors unable to attend voting station

5. Despite section 79(1) and (3) of the Act, where an elected authority has passed a bylaw in accordance with section 160(2) of the Act,
 - (a) the elected authority may define lodge accommodation as a home, including a self-contained housing unit, for the use of persons of advanced years who
 - (i) are not suffering from any chronic disease that incapacitates them, and

(ii) may or may not be capable of or desirous of maintaining their own housing accommodation,

and

(b) the returning officer of the elected authority may appoint the number of deputies that the returning officer considers necessary to take the votes of electors who reside in lodge accommodation, as defined under clause (a), and are unable to attend a voting station or advance voting station to vote.

Repeal

6. The *Modified Voting Procedure Regulation* (AR 170/2000) is repealed.

Expiry

7. For the purpose of ensuring that this Regulation is reviewed for ongoing relevancy and necessity, with the option that it may be repassed in its present or an amended form following a review, this Regulation expires on November 30, 2016.

SAMPLE APPLICATION TO USE MODIFIED VOTING PROCEDURE

Alberta Municipal Affairs and Housing
Local Government Services Division
17th Floor, Commerce Place
10155 - 102 Street
Edmonton, Alberta
T5J 4L4

Dear Sir:

Re: Modified Voting Procedure

Please be advised that on _____ (date) Council passed the following resolution:

“Moved by Councillor _____ (name).

That the *Local Authorities Election Act* permits the operation of only one voting station for each voting subdivision the _____ (name of municipality) hereby applies to Municipal Affairs and Housing for an Order authorizing the Council of the _____ (name of municipality) to pass a bylaw permitting the returning officer to designate more than one voting station in a subdivision.”

“Carried.”

Accordingly, Council hereby applies for the necessary Ministerial Order authorizing the passing of a (bylaw to use) the modified voting system established by Regulation No. 5/2007.

Yours truly,

(CAO, Manager, etc.)

SAMPLE BYLAW TO ADOPT THE MODIFIED VOTING PROCEDURE

(Name of Municipality)

Bylaw # _____

BEING A BYLAW TO ADOPT A MODIFIED VOTING PROCEDURE

Pursuant to the Provisions of the *Local Authorities Election Act*, Revised Statutes of Alberta, 2000 and amendments thereto, and under the authority of Ministerial Order number: _____, the Council of _____, in the Province of Alberta, enacts as follows:

- 1. The _____ hereby adopts the modified system of conducting an election as prescribed by Alberta Regulation No. 5/2007 and amendments.
- 2. The modified voting procedure shall be used for the purpose of conducting elections pursuant to the provisions of the *Local Authorities Election Act*.
- 3. This bylaw shall come into force and effect upon the date of the passing of the third and final reading.

Read a first time _____

Read a second time _____

Read a third time _____

and finally passed this _____ day of _____, 20_____.

Date signed _____

CEO (Mayor, Reeve)

CAO

A SUGGESTED VOTING STATION ARRANGEMENT

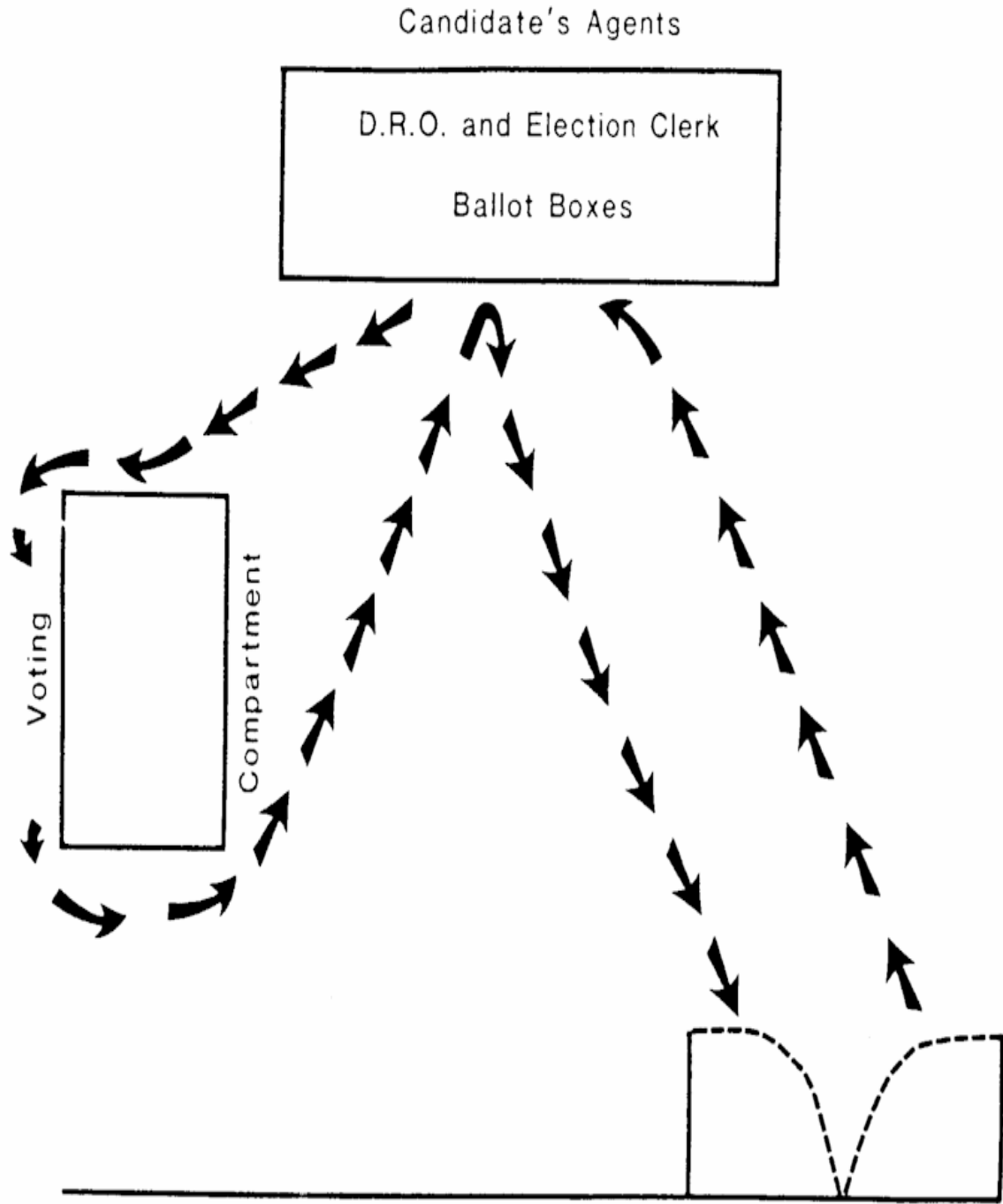

SMALL TO MEDIUM JURISDICTION

A SUGGESTED VOTING STATION ARRANGEMENT

Error! Bookmark not defined.

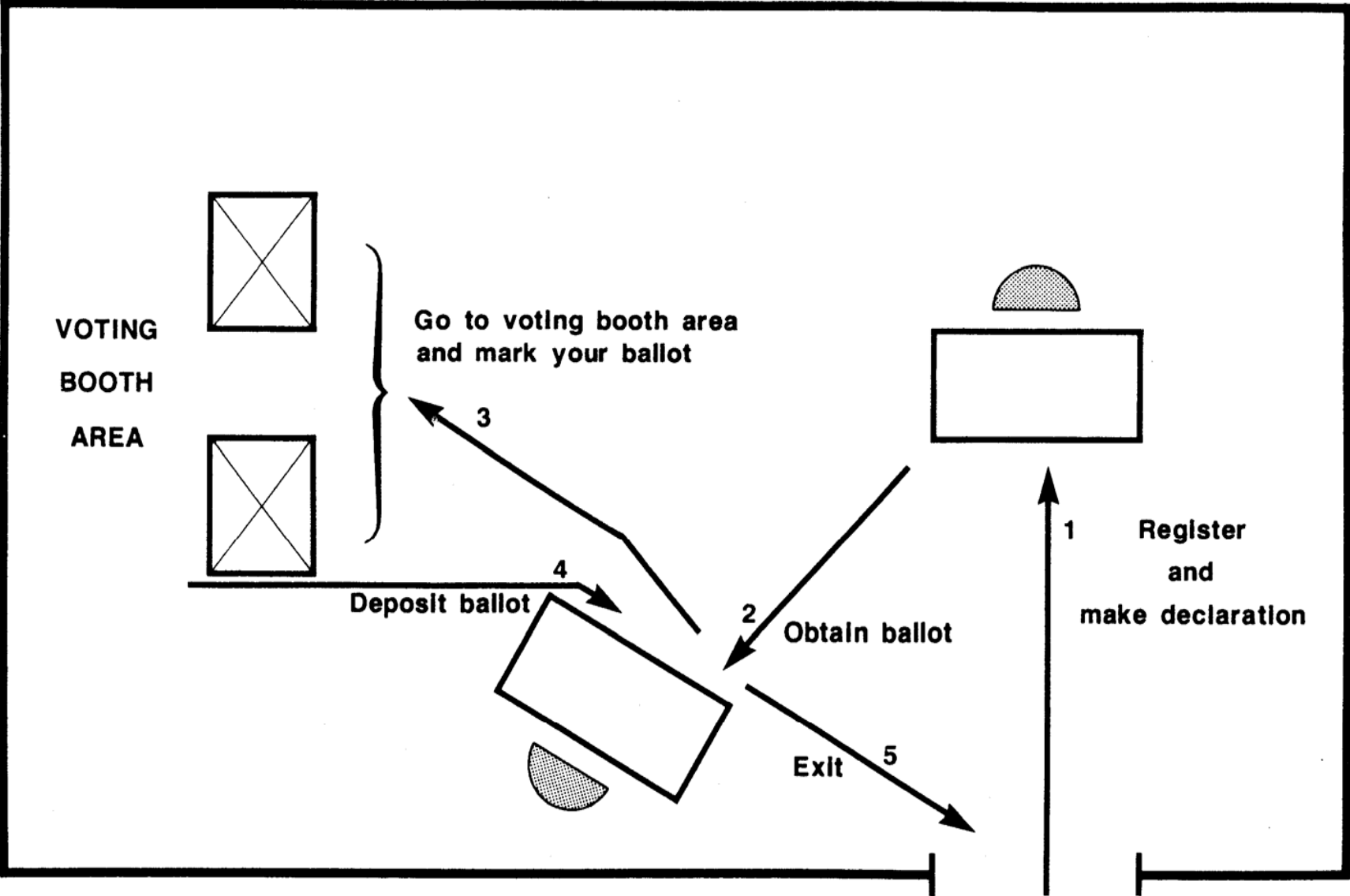

A SUGGESTED VOTING STATION ARRANGEMENT

Error! Bookmark not defined.

